

REVISIONS				
SHEET	REV	DESCRIPTION	DATE	APPROVED

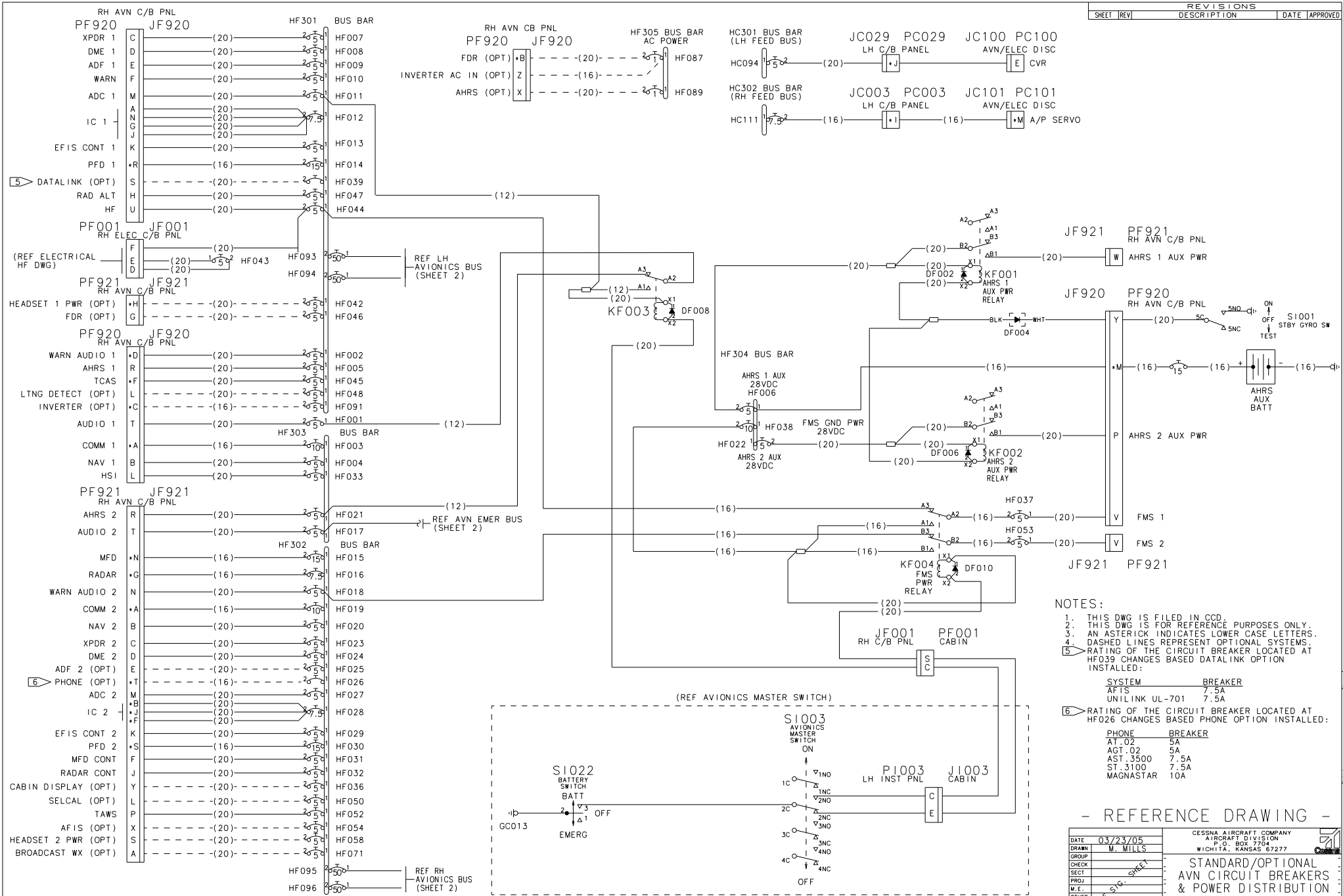

- NOTES:
- THIS DWG IS FILED IN CCD.
 - THIS DWG IS FOR REFERENCE PURPOSES ONLY.
 - AN ASTERICK INDICATES LOWER CASE LETTERS.
 - DASHED LINES REPRESENT OPTIONAL SYSTEMS.
 - RATING OF THE CIRCUIT BREAKER LOCATED AT HF039 CHANGES BASED DATALINK OPTION INSTALLED:

SYSTEM	BREAKER
AFIS	7.5A
UNILINK UL-701	7.5A
PHONE	BREAKER
ACT 02	5A
ACT 02	5A
AST.3500	7.5A
ST.3100	7.5A
MAGNASTAR	10A

- REFERENCE DRAWING -

DATE	03/23/05	CESSNA AIRCRAFT COMPANY
DRAWN	M. MILLS	AIRCRAFT DIVISION
GROUP		P.O. BOX 7704
CHECK		WICHITA, KANSAS 67277
SECT		
PROJ		
M.E.		
OTHER		
FABRICATE PER	CSAW005	DWG NO.
PROCESS PER		F71379
WIRE TERMINATION PER	CS62716	8618213
		SCALE: SCL

8618213 1 EC 058771

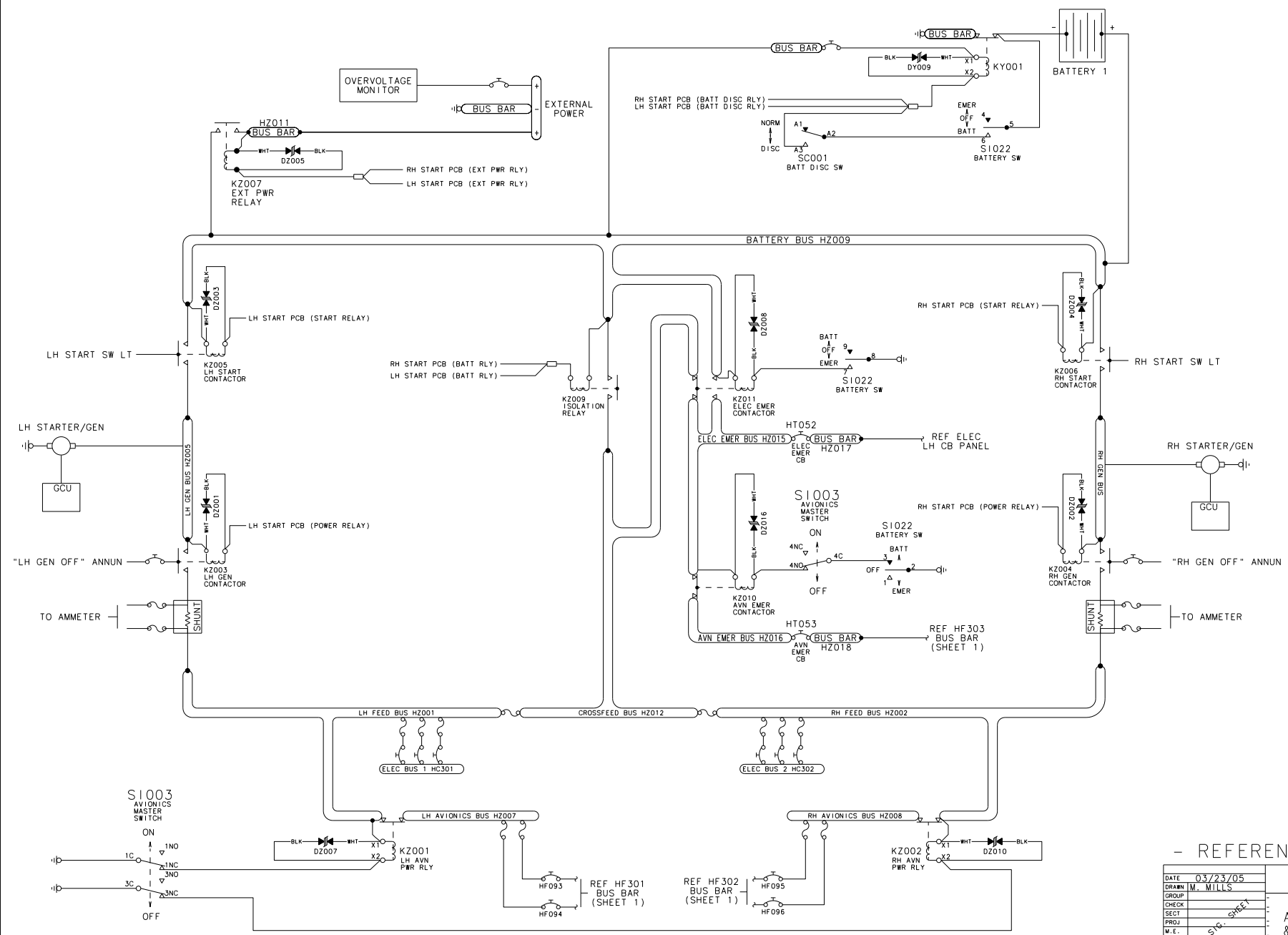

- REFERENCE DRAWING -

DATE	03/23/05	CESSNA AIRCRAFT COMPANY AIRCRAFT DIVISION P.O. BOX 7704 WICHITA, KANSAS 67277
DRAWN	M. MILLS	
CHECK		STANDARD/OPTIONAL AVN CIRCUIT BREAKERS & POWER DISTRIBUTION
SECT		
PROJ		
W.E.		
OTHER		
FABRICATE PER	CSAM005	SIZE FROM NO.
PROCESS PER	CSA223/CSA555/555	DWG NO.
WIRE TERMINATION PER	CSA223/16	SCALE

8618213

8618213