

NOTES:

1. AFFIX CM2987-1 ID TAG NEAR CONNECTOR.
2. REFER TO 8654500 FOR LIGHTING/GROUND BLOCK LOCATION.
3. ALL SINGLE CONDUCTOR WIRE SHALL BE PER M81044/12-XX-9.
4. AMP INC., HARRISBURG, PA.
5. S2353-7 IS CESSNA STANDARD PART NUMBER FOR 66099-1 PIN.
6. S2350-2 IS CESSNA STANDARD PART NUMBER FOR 206061-1 CONNECTOR.
7. S2351-2 IS CESSNA STANDARD PART NUMBER FOR 206062-1 CONNECTOR.
8. MISC. HARDWARE: M81824/1-1 SPLICE

REVISIONS			
SHEET	REV	DESCRIPTION	DATE APPROVED
	A	REVISED WITH CHANGES: 1) PART # WAS 2-203735-6, ADDED S2351-2 BACKSHELL 2) ADDED FLAGNOTES 6 & 7 EFF: EC 34158 WO XL-0150	04/05/96 RBS
	B	REVISED WITH CHANGES: 1) CHANGED PART NUMBER FROM M39029/22-191 TO M39029/22-192. EFF: EC 34158 WO XL-0530	07/31/96 SAS
	C	BY REVISION: 1) DELETED THE FOLLOWING WIRES: 3J1010-DU1921A EU1921A-DU1921B 2) ADDED THE FOLLOWING WIRES: 3J1010-DU1921B EU1923B-DU1921A HU1920A-17PF701 CU1921B-50PF701 GU1921B-33PF701 HU1922B-15PF701 HD3022-18PF701 6PF301-47PF701 3) PLACEMENT OF JUNCTION BLOCKS AND WIRES ON THE FACE OF THE DRAWING CHANGED IN ORDER TO CLEARLY SHOW THE REVISED WIRING. 4) ADDED FLAGNOTE 8. EFF: EC 34158 WO XL-1014	01/20/97 RBS

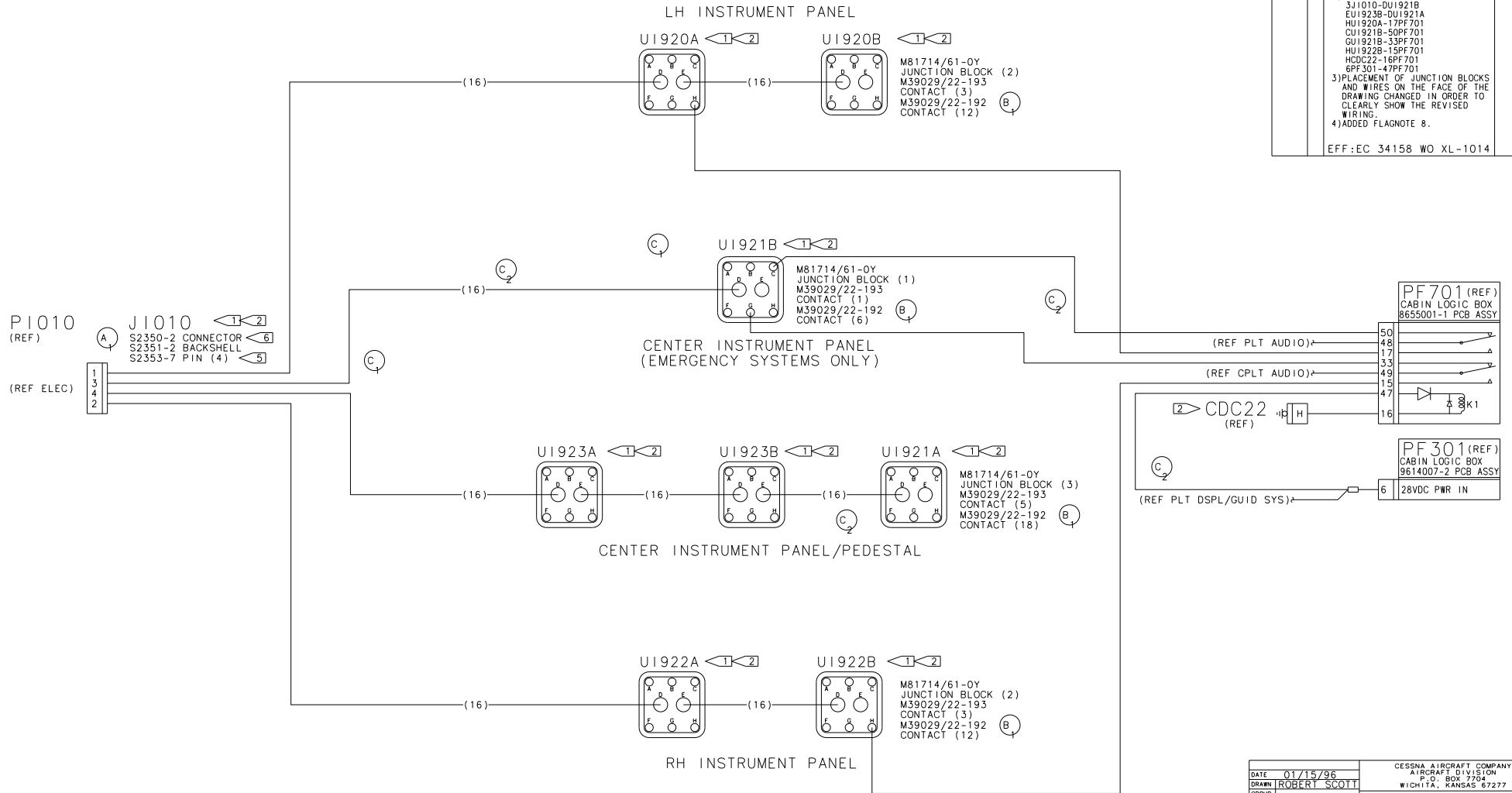

DATE	01/15/96	CESSNA AIRCRAFT COMPANY
DRAWN	ROBERT SCOTT	AIRCRAFT DIVISION
CHECK		P. O. BOX 7704
SECT		WICHITA, KANSAS 67277
PROJ		
M.E.		
OTHER		
FABRICATE PER	CESS2808	
PROCESS PER	CESS2808	
WIRE TERMINATION PER	CESS2716	
SIZE	F71379	8618102
SCALE	SCL	

8618102 EC 34158