

NOTES:

- REFER TO AVIONICS COLLECTOR KIT FOR GROUND BLOCK/STUD INSTALLATION.
- PERMISSIBLE TO DEVIATE FROM HIRF REQUIREMENTS AS DEFINED IN CSAM012.
- ALL WIRE PER MIL-W-81044/12, 22 AWG, EXCEPT AS NOTED.
- TWISTED SHIELDED PAIR ASCB BUS WIRES (24AWG) P/N CM3928-1 ARE TO BE INSTALLED PER CSPA 055 WHERE THE MINIMUM WIRE LENGTH BETWEEN THE USERS OR STUBS IS 23 INCHES.
- TWISTED PAIR ASCB STUB BUS WIRES (24AWG) P/N CM3928-1 ARE TO BE INSTALLED PER CSPA 055 WHERE THE MAXIMUM STUB BUS WIRE LENGTH IS 10 INCHES.
- AN ASTERISK PRECEDING A LETTER INDICATES LOWER CASE.
- PERMISSIBLE TO SUBSTITUTE SHIELD BRAID WITH 22AWG WIRE AS NECESSARY.
- REF NOSE EQUIPMENT INSTALLATION FOR 9255007-6 (REF) MODULE LOCATION.
- REF SIDE CONSOLE EQUIPMENT INSTL FOR 9255007-6 (REF) MODULE LOCATION.

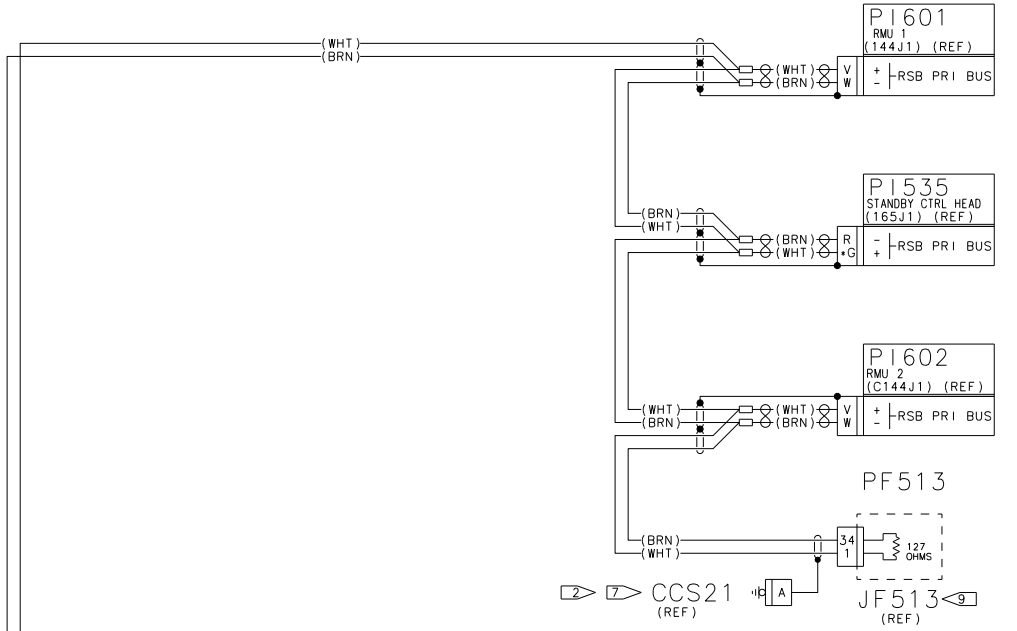
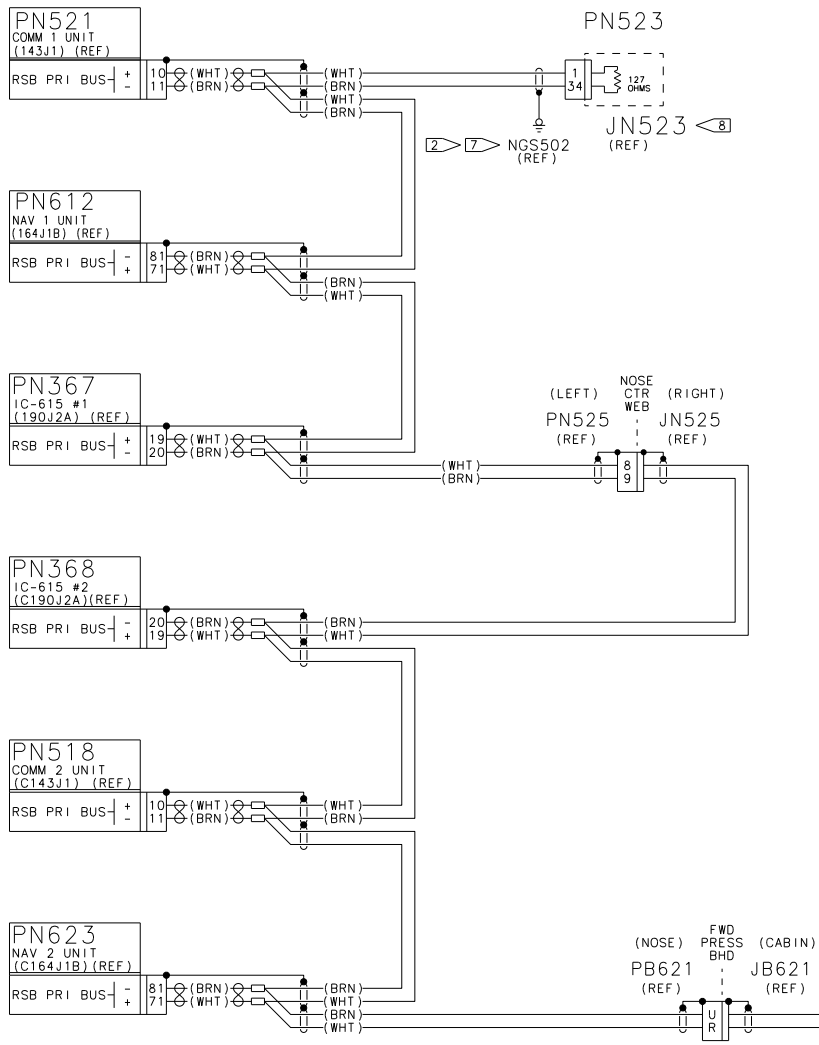

PRIMARY RADIO SYSTEM BUS

DATE	10/16/02	CESSNA AIRCRAFT COMPANY AIRCRAFT DIVISION P. O. BOX 7704 WICHITA, KANSAS 67277	
DRAWN	S. WALLACE		
GROUP		C/A - RADIO/AUDIO RSB BUSSING W/OUT DME INDICATORS	
CHECK			
SECT			
PROJ			
M.E.			
OTHER			
FABRICATE PER CSAM005		SIZE FSCM NO.	DRG NO.
PROCESS PER 3345A0000000		F71379	8615173
WIRE TERMINATION PER 3522716		SCALE NONE	PARENT 8615171
			SHEET 1 OF 3

REVISIONS				
SHEET	REV	DESCRIPTION	DATE	APPROVED

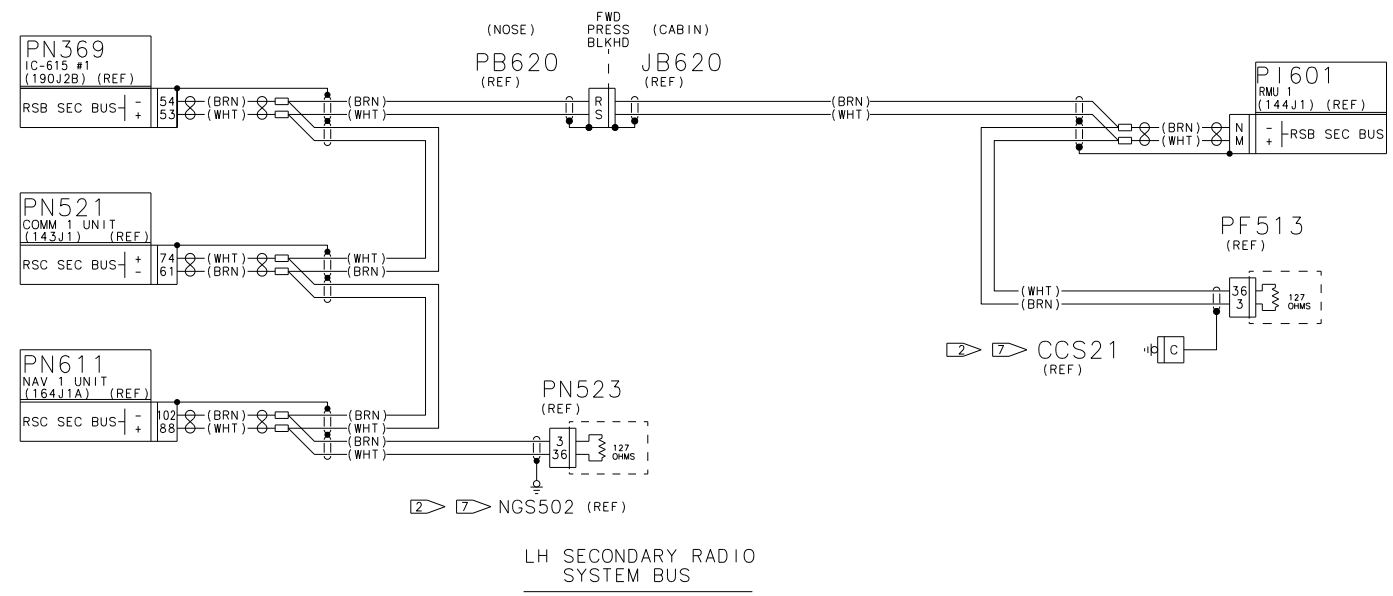
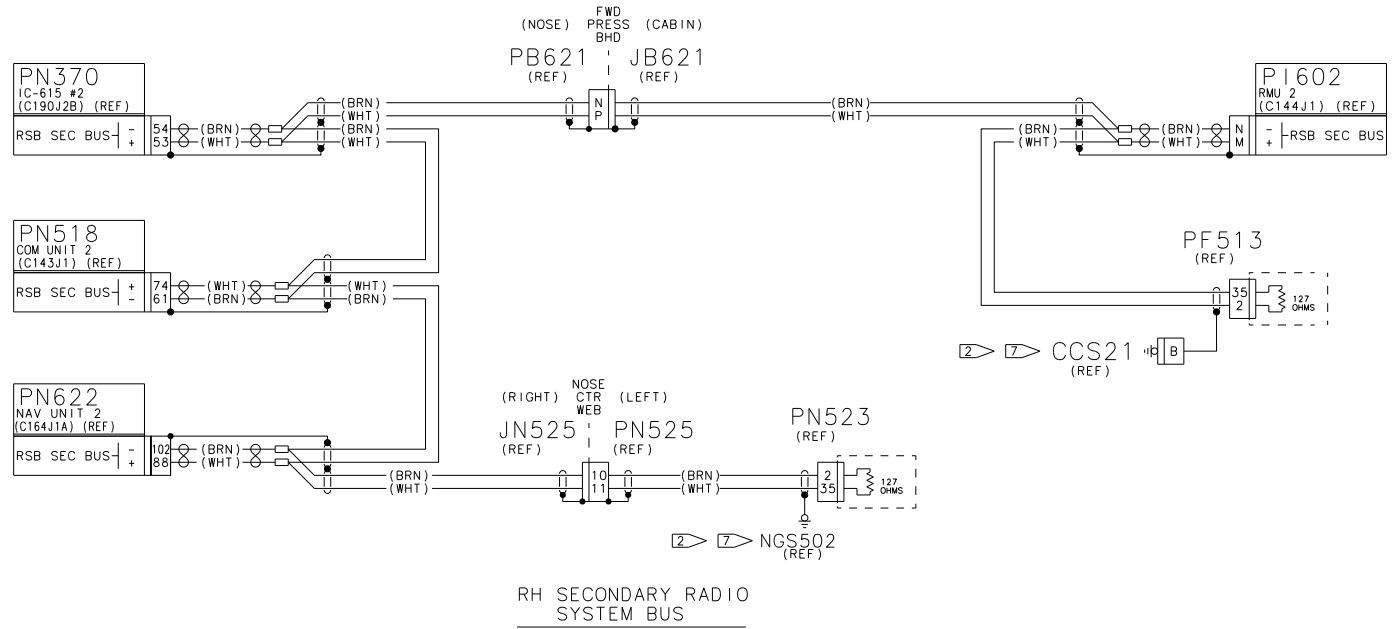

DATE	10/16/02	CESSNA AIRCRAFT COMPANY		
DRAWN	S. WALLACE	AIRCRAFT DIVISION		
CHECK		P. O. BOX 7704		
SECT		WICHITA, KANSAS 67277		
PROJ		C/A - RADIO/AUDIO		
M.E.		RSB BUSSING W/OUT		
OTHER		DME INDICATORS		
FABRICATE PER	CSAMDS	SIZE	FSM NO.	DRG NO.
PROCESS PER	SAKSAKAKAK	F71379		8615173
WIRE TERMINATION PER	SESZ716	SCALE	NONE	SHEET 2 OF 3

8615173

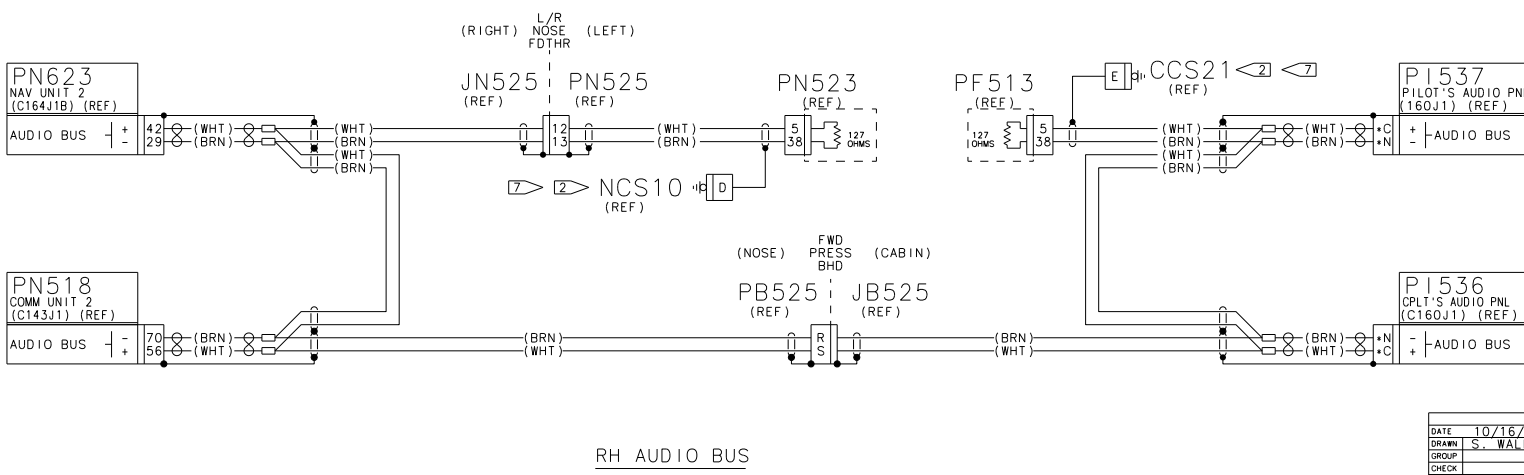
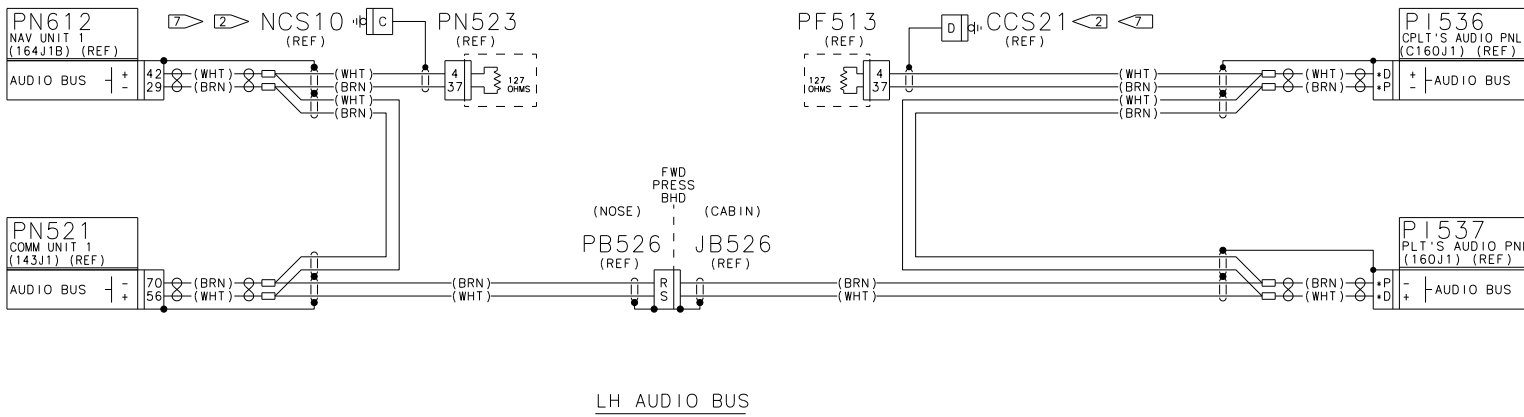

DATE	10/16/02	CESSNA AIRCRAFT COMPANY	
DRAWN	S. WALLACE	AIRCRAFT DIVISION	
GROUP		P. O. BOX 7704	
CHECK		WICHITA, KANSAS 67277	
SECT		C/A - RADIO/AUDIO	
PROJ		RSB BUSSING W/OUT	
M.E.		DME INDICATORS	
OTHER			
FABRICATE PER	CSAMDS	SIZE	FSM NO.
PROCESS PER	XXXXXXXXXX	F71379	DWG NO.
WIRE TERMINATION PER	SESZ716	SCALE	NONE
			8615173

8615173