

REVISIONS				
SHEET	REV	DESCRIPTION	DATE	APPROVED
	B	REDRAWN WITH CHANGES: 1) COMPLETELY REDRAWN.	6/13/02 GSS	SEE SIGNATURE SHEET
EFF: ECR50723				

NOTES:

1. THIS DRAWING FILED IN CCD.
- 2 > AFFIX CM2987-5 ID TAG NEAR PLUG IDENTIFYING ASSEMBLY P/N & NAME.
- 3 > SCOTT AVIATION, LANCASTER, NY.
4. ALL SINGLE CONDUCTOR WIRE PER MIL-W-81044/12-XX-9 SHIELDED SINGLE CONDUCTOR WIRE PER M27500-XXML1T08 XX = 22 AWG, EXCEPT AS NOTED.
- 5 > APPLY HEAT SHRINK SLEEVING TO PROTECT ALL EXPOSED ELECTRICAL CONNECTIONS.
- 6 > AMPHENOL CORP., SIDNEY, NY.
- 7 > DRESS OUT WIRES SUCH THAT THEY EXIT THE J2 JACK AT APPROX 90°. THIS IS TO FACILITATE THE INSTALLATION OF THE UPHOLSTERY PANEL THAT INSTALLS IN CLOSE PROXIMITY TO THE OXYGEN BOX. REFER TO THE J2 ASSY ILLUSTRATIONS.
 - APPLY SHRINK SLEEVING TO ALL SOLDER POINTS.
 - INSTALL STRAIN RELIEF LOOP TO WIRING & TIE WRAP TO J2 JACK.
 - USE MS25171-2S (REF) PLASTIC BOOT TO PROTECT INSULATION.
8. MISCELLANEOUS PARTS
52974N2 SOLDER SLEEVE

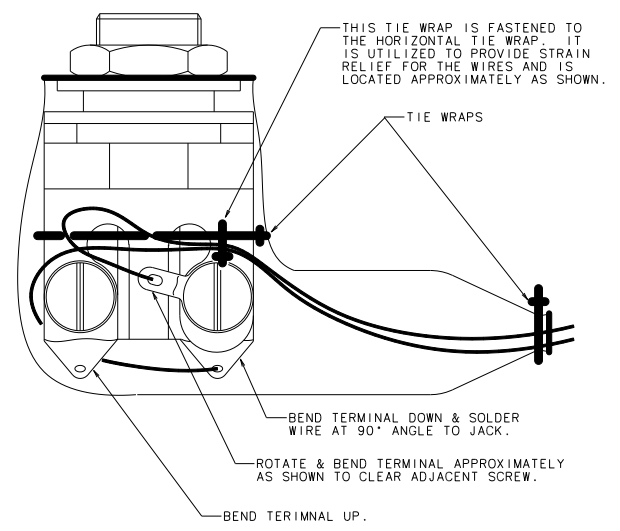

J2 ASSY-TOP VIEW
(SHRINK SLEEVING ON SOLDER TERMINALS OMITTED FOR CLARITY)

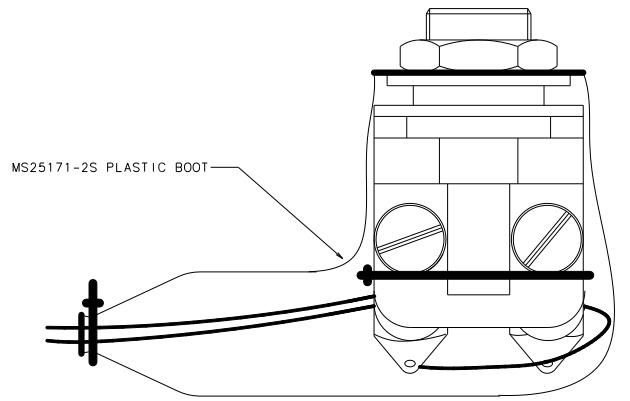

J2 ASSY-BOTTOM VIEW
(SHRINK SLEEVING ON SOLDER TERMINALS OMITTED FOR CLARITY)

DATE	7/27/99	CESSNA AIRCRAFT COMPANY
DRAWN	GARY SCHWEIZER	AIRCRAFT DIVISION
GROUP		P.O. BOX 7704
CHECK		WICHITA, KANSAS 67277
SECT		
PROJ		
M.E.		
OTHER		
FABRICATE PER: CES2806		SIZE (FSW NO.)
PROCESS PER: XXXXXXXXXX		DWG NO.
WIRE TERMINATION PER: SC22216		F71379 8615134
SCALE: SCL PARENT: 8615116 SHEET 1 OF 1		

8615134 B B EC43454