

NOTES:

1. THIS DRAWING FILED IN CCD.
2. UNSHIELDED WIRE SHALL BE PER M81044/12-XX-9 (XX = 22 AWG, EXCEPT AS NOTED).
3. SLEEVE ALL EXPOSED SOLDER TERMINALS WITH HEAT SHRINK SLEEVING.

REVISIONS				
SHEET	REV	DESCRIPTION	DATE	APPROVED

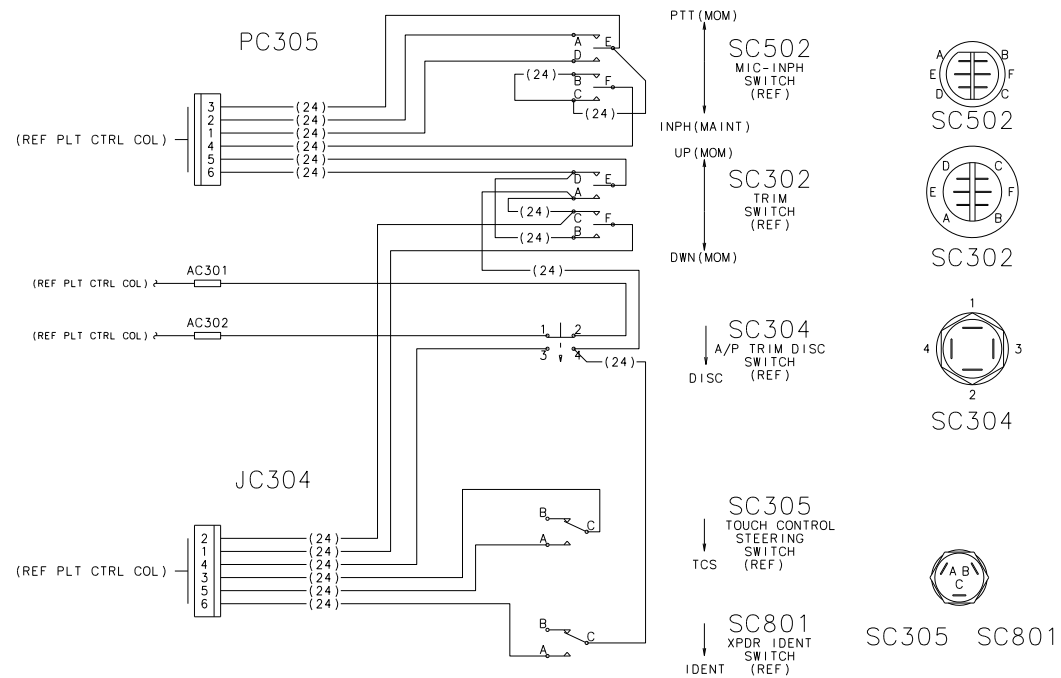

DATE: 5/20/2003		CESSNA AIRCRAFT COMPANY	
DRAWN: GARY SCHWEIZER		AIRCRAFT DIVISION	
GROUP:		P. O. BOX 7704	
CHECK:		WICHITA, KANSAS 67277	
SECT:		CABLE ASSY- PILOT'S CONTROL WHEEL	
PROJ:			
M.E.:			
OTHER:			
FABRICATE PER: CSAMDS		SIZE: F71379	DWG NO.: 8612161
PROCESS PER: XXXXXXXXXX		SCALE:	PARENT: 8612103 SHEET 1 OF 1
WIRE TERMINATION PER: SESZ716			

8612161 1 EC 52743