

PN611	
NAV UNIT 1 (164J1A)	
L SEC RSB (H)	88
L SEC RSB (L)	102
NAV AUX DATA (H)	70
NAV AUX DATA (L)	58
NAV AUX CLK (H)	69
NAV AUX CLK (L)	72
MLS1 RCB RCVR (H)	25
MLS1 RCB XMIT (H)	21
MLS1 RCB RCVR (L)	38
MLS1 RCB XMIT (L)	34
DME 28V RETURN	95
DME 28V RETURN	83
DME +28VDC IN	86
DME +28VDC IN	99
MUTE SUPP	42
VOR/ILS RS422 (L)	59
CLUSTER GND	103
NAV +28VDC IN	85
NAV +28VDC IN	98
G/S SUPERFLAG	74

PN612	
NAV UNIT 1 (164J1B)	
NAV +28VDC IN	39
NAV +28VDC IN	52
CLUSTER GND	98
NAV PWR GND	38
NAV PWR GND	50
VOR/ILS RS422 (H)	89
VOR/GS DEV COM	75
G/S DEV + DWN	79
VID COMPOSITE (H)	21
VID COMPOSITE (L)	22
ILS ENRGZ (GND)	64
PRI RSB (H)	71
PRI RSB (L)	81
DIG AUDIO (H)	42
DIG AUDIO (L)	29
AUX SHIFT LD (H)	90
AUX SHIFT LD (L)	88
+28VDC FAN PWR	2
28VDC FAN RTN	44
NAV EMER AUD (H)	36
NAV EMER AUD (L)	51
STRAP DATA	58
STRAP +5VDC	40
SIDE SPARE	57
STRAP GND	26
SIDE SELECT	80
STRAP CLOCK	59
STRAP WD LOAD	84

PN613	
(NAV STRAPPING BOARD ASSY)	
7	E1
7	E3
7	E4
7	E8
7	E6
7	E2

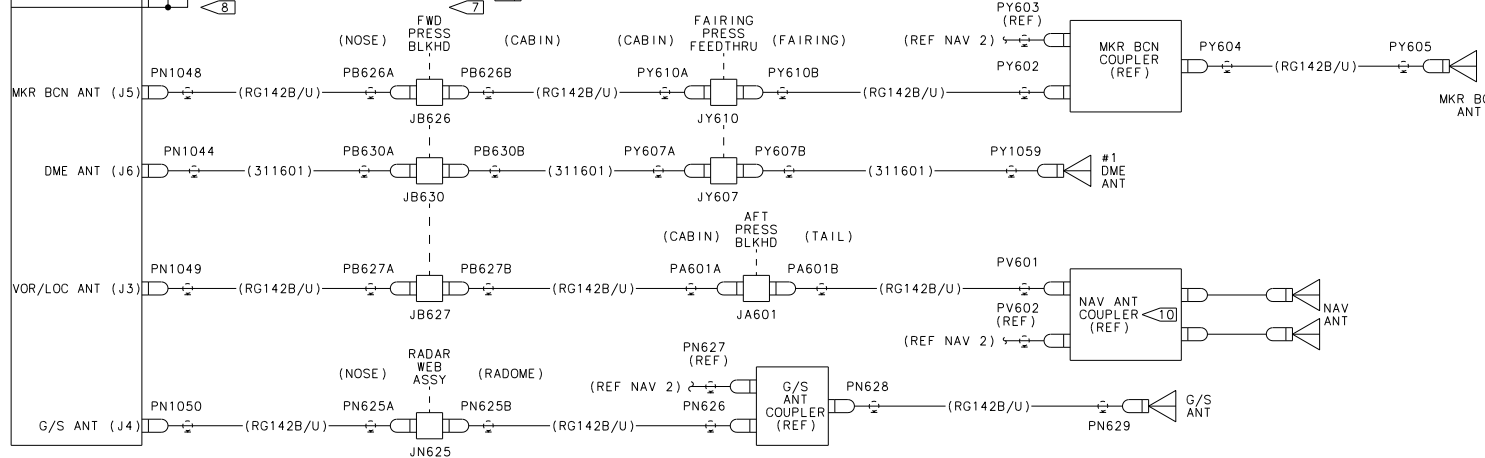
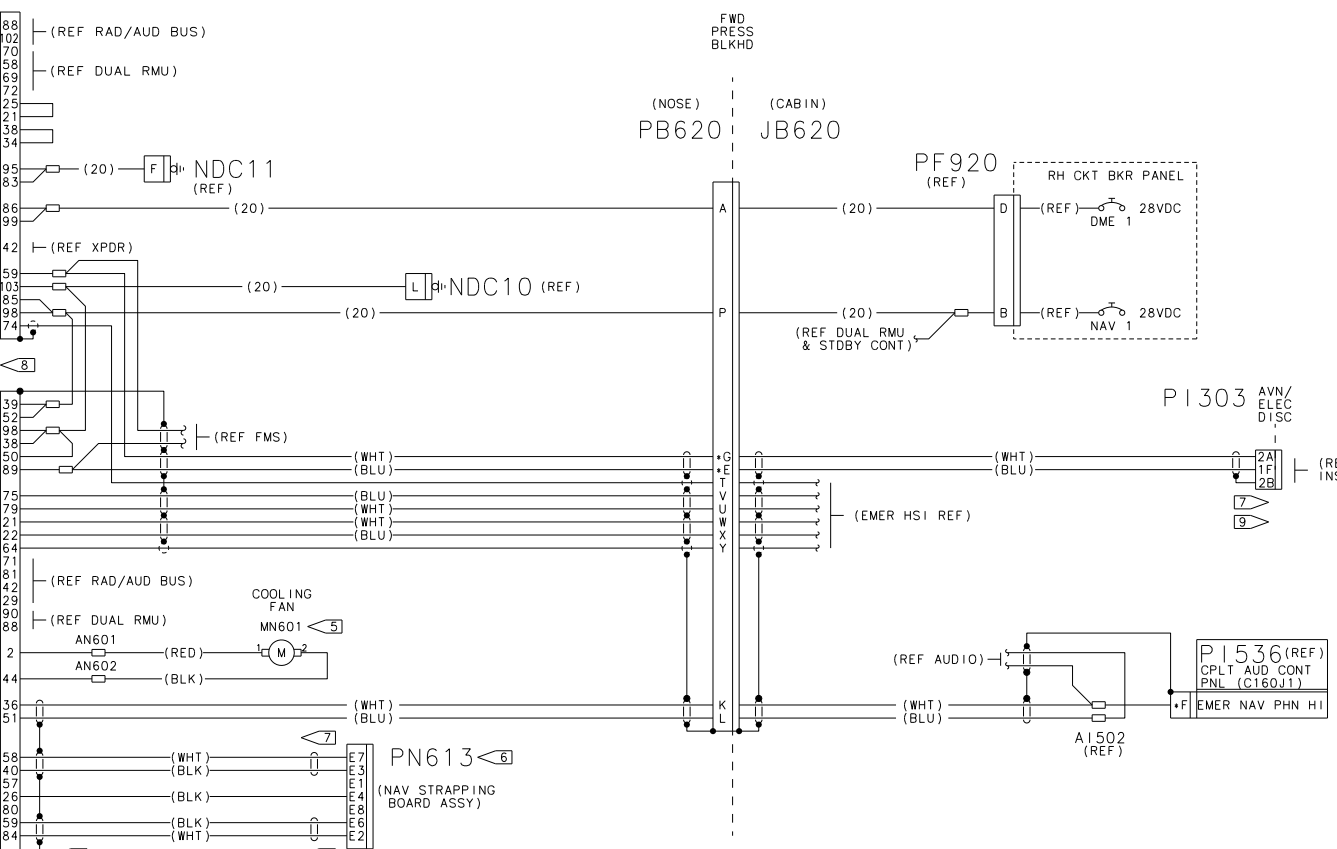

- NOTES:**
- THIS DRAWING IS FILED IN CCD.
 - AN ASTERISK PRECEDING A LETTER INDICATES LOWER CASE.
 - UNSHIELDED SINGLE CONDUCTOR WIRE PER M81044/12-XX-9. SHIELDED SINGLE CONDUCTOR WIRE PER M27500-XXML1T08. SHIELDED TWO CONDUCTOR WIRE PER M27500-XXML2T08. (XX=22 AWG, EXCEPT AS NOTED)
 - FOR GND BLOCK/STUD LOCATIONS, REFER TO GND BLOCK/STUD INSTALLATION DRAWING CALLED OUT ON THE AVIONICS INSTALLATION KIT.
 - COOLING FAN & WIRES ARE FURNISHED AS PART OF NAV TRAY. REFERENCE NOSE EQUIPMENT INSTL DWG FOR P/N.
 - STRAP BOARD CONNECTOR, GROMMET & WIRE ARE FURNISHED AS PART OF STRAP ASSY KIT CALLED OUT IN NOSE EQUIP INSTALLATION. REFER TO P/L NOTE 1 FOR INDIVIDUAL KIT P/N BREAKDOWN.
 - PERMISSIBLE TO DEVIATE FROM HIRF REQUIREMENTS AS DEFINED BY CSAM012.
 - TERMINATE SHIELD BRAID AT GROUND STUD ON RACK.
 - PERMISSIBLE TO SUBSTITUTE BRAID SHIELD WITH 22 AWG WIRE.
 - NAV ANTENNA COUPLER IS FURNISHED AS PART OF ANTENNA KIT. REFERENCE ANTENNA INSTALLATION DRAWING FOR P/N.

DATE	01/6/05	CESSNA AIRCRAFT COMPANY
DRAWN	J. OPLTGER	AIRCRAFT DIVISION
CHECK		P.O. BOX 7704
GROUP		WICHITA, KANSAS 67277
SECT		
PROJ		
M.E.		
OTHER		
FABRICATE PER CSAM012		SIZE FSCM NO.
PROCESS PER XXXXXXXXXX		DRG NO.
WIRE TERMINATION PER 2552216		F71379 8603113
SCALE:	PARENT 8603111	SHEET 1 OF 1

8603113 1