

REVISIONS				
SHEET	REV	DESCRIPTION	DATE	APPROVED
	B	REDRAWN WITH CHANGES: 1) COMPLETELY REDRAWN.	6/13/02 CGS	SEE SIGNATURE SHEET
EFF: ECR50723				

NOTES:

- THIS DRAWING FILED IN CCD.
- AFFIX CM2987-5 ID TAG NEAR PLUG IDENTIFYING ASSEMBLY P/N & NAME.
- SCOTT AVIATION, LANCASTER, NY.
- ALL SINGLE CONDUCTOR WIRE PER MIL-W-81044/12-XX-9 SHIELDED SINGLE CONDUCTOR WIRE PER M27500-XXML1T08 XX = 22 AWG. EXCEPT AS NOTED.
- APPLY HEAT SHRINK SLEEVING TO PROTECT ALL EXPOSED ELECTRICAL CONNECTIONS.
- AMPHENOL CORP., SIDNEY, NY.
- DRESS OUT WIRES SUCH THAT THEY EXIT THE J2 JACK AT APPROX 90°. THIS IS TO FACILITATE THE INSTALLATION OF THE UPHOLSTERY PANEL THAT INSTALLS IN CLOSE PROXIMITY TO THE OXYGEN BOX. REFER TO THE J2 ASSY ILLUSTRATIONS.
 - APPLY SHRINK SLEEVING TO ALL SOLDER POINTS.
 - INSTALL STRAIN RELIEF LOOP TO WIRING & TIE WRAP TO J2 JACK.
 - USE MS25171-2S (REF) PLASTIC BOOT TO PROTECT INSULATION.
- MISCELLANEOUS PARTS
S2974N2 SOLDER SLEEVE

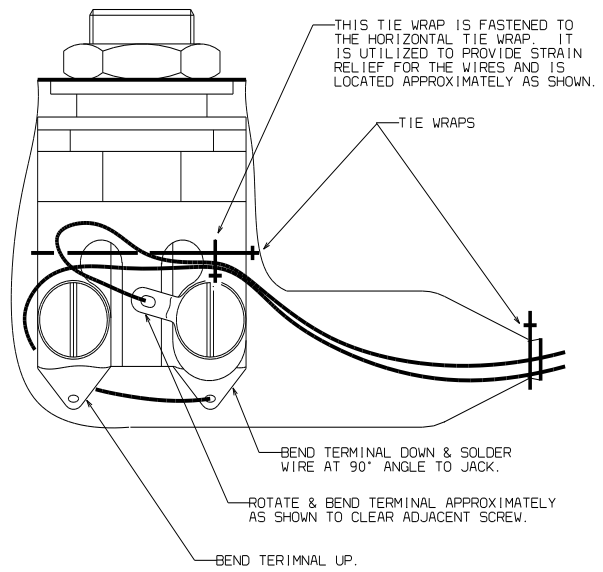

J2 ASSY-TOP VIEW
(SHRINK SLEEVING ON SOLDER TERMINALS OMITTED FOR CLARITY)

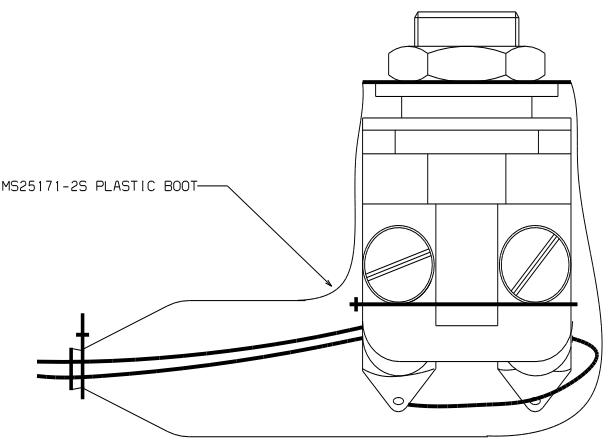

J2 ASSY-BOTTOM VIEW
(SHRINK SLEEVING ON SOLDER TERMINALS OMITTED FOR CLARITY)

DATE	7/27/99	CESSNA AIRCRAFT COMPANY	
DRAWN	GARY SCHWEIZER	AIRCRAFT DIVISION	
CHECK		P.O. BOX 7704	
SECT		WICHITA, KANSAS 67277	
PROJ		C/A-EROS OXYGEN MASK	
M.E.		ADAPTER CABLE	
OTHER	SEE STD. SHEET	SIZE (FSM NO.)	DWG NO.
FABRICATE PER	CES2600	F 71379	8615134
PROCESS PER	XXXXXXXXXXXX	SCALE-SCL	PARENT: 8615116
WIRE TERMINATION PER	CES2716		SHEET 1 OF 1