

NOTES:

- 1 DEUTSCH CO. BANNING, CA.
- 2 DME ELECTRONICS WICHITA, KS.
- 3. ALL WIRE TO BE PER MIL-W-81044/12, 22 AWG, EXCEPT AS NOTED.
- 4. SLEEVE ALL EXPOSED SOLDER TERMINALS WITH HEAT SHRINK SLEEVING.

REVISIONS				
SHEET	REV	DESCRIPTION	DATE	APPROVED
	A	BY REVISION: 1) CHANGED SPLICE P/N: WAS DME-22 NOW DME-20 CHANGES MADE TO ANSWER PROBLEM WORKSHEET P151-250 EFF: EC 34158 WO XL-0877	11/11/96 CRV	

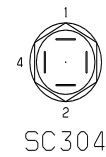
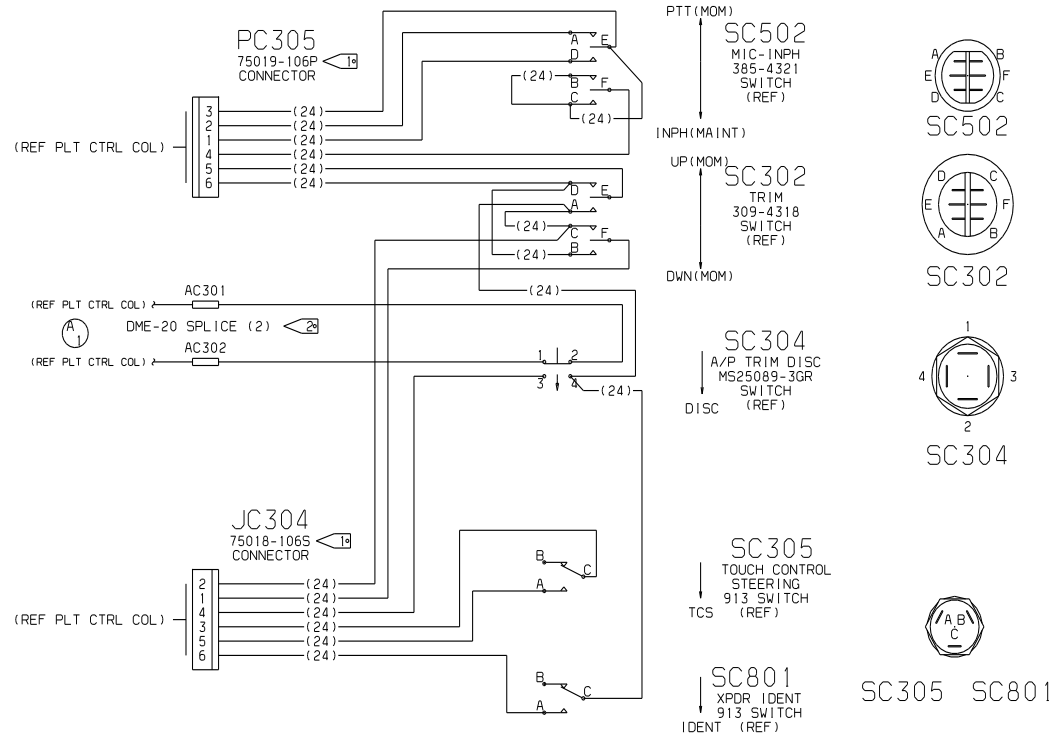

SC801

DATE	02/06/96	CESSNA AIRCRAFT COMPANY
DRAWN	ROBERT SCOTT	AIRCRAFT DIVISION
GROUP		P.O. BOX 7704
CHECK		WICHITA, KANSAS 67277
SECT		
PROJ		CABLE ASSY -
M. E.		PILOT'S
OTHER		CONTROL WHEEL
FABRICATE PER	CESS260A	SIZE
PROCESS PER	XXXXXXXXXXXXXX	F 71379
WIRE TERMINATION PER	CESS271E	DWG NO.
		SCALE:

EC 34158
 SHEET 1 OF 1