

REVISIONS				
SHEET	REV	DESCRIPTION	DATE	APPROVED
A	BY	REVISION: 1) REF PB1039A WAS UG88C/U CHANGED TO UG913A/U	09/10/96 CRV	
EFF: EC 34154 XL-0668				

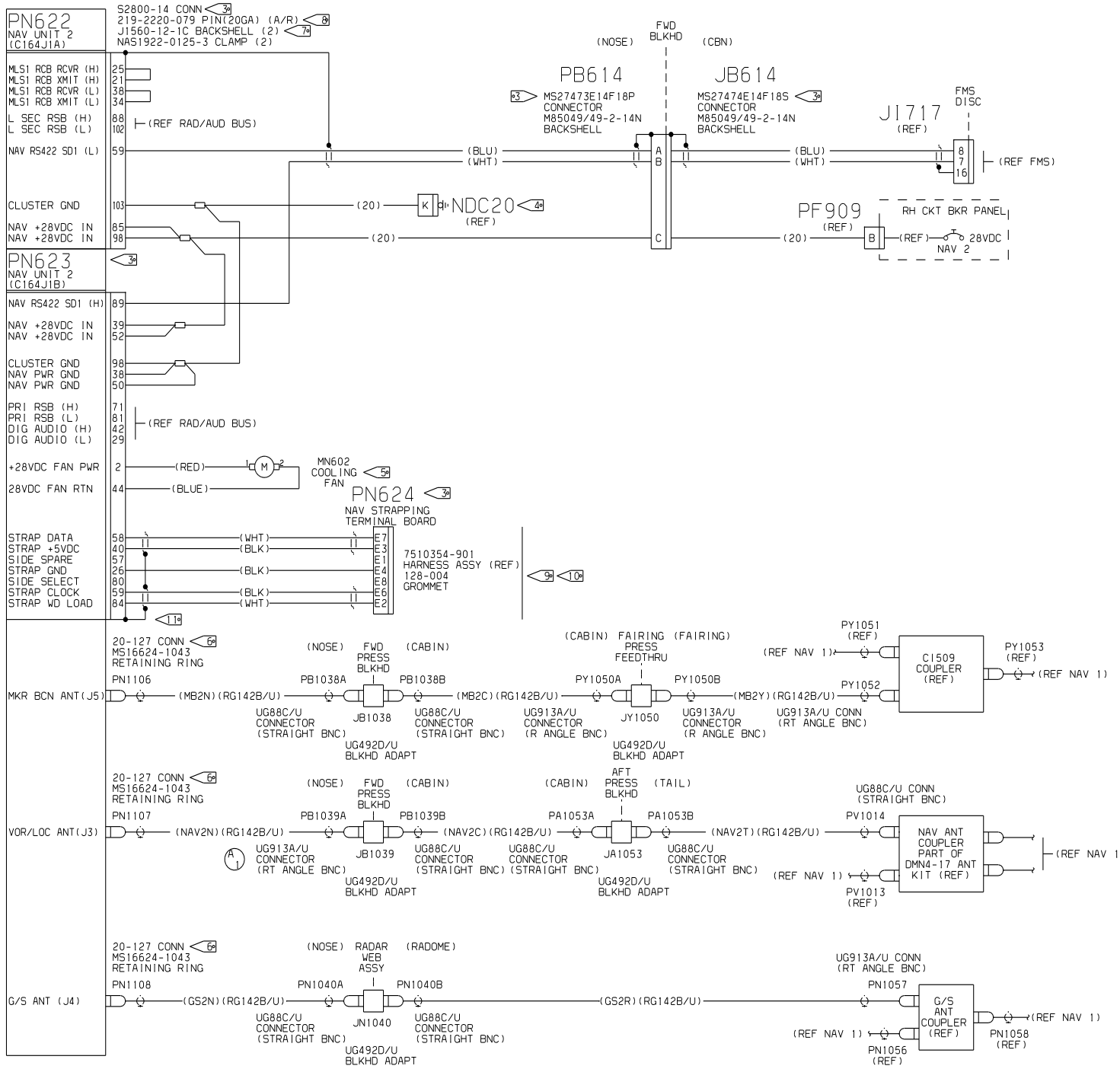

NOTES:

- ALL SINGLE CONDUCTOR WIRE SHALL BE PER M81044/12-XX-9 SHIELDED PAIR CONDUCTOR PER M27500-(XX)ML2T08. (XX=22 AWG EXCEPT AS NOTED)
 - MISC HARDWARE:
 - M81824/1-1 SPLICE
 - M81824/1-2 SPLICE
 - S2974N3 SLEEVE
 - S1367-1-6 TERMINAL
 - S1367-1-8 TERMINAL
- 33 AFFIX CM2987-1 ID TAG NEAR CONNECTOR.
 34 REFER TO 8654500 FOR GND BLOCK/STUD LOCATION.
 35 COOLING FAN & WIRES FURNISHED AS PART OF THE 7510107-973 NAV INSTL KIT HONEYWELL INC. GLENDALE, AZ.
 36 P/N OF TED MFG CORPORATION, SHAWNEE MISSION, KS.
 37 P/N OF SUNBANK ELECTRONICS, PASO ROBLES, CA.
 38 P/N OF TRI STAR ELECTRONICS, VENICE, CA.
 39 STRAP BOARD CONNECTOR, GROMMET AND WIRES. FURNISHED AS PART OF 7510359-953 (REF) STRAP ASSY KIT HONEYWELL INC., GLENDALE, AZ.
 40 REFER TO 8654001 FOR INSTALLATION OF STRAP BOARD ENCLOSURE
 41 TERMINATE SHIELD BRAID AT GROUND STUD ON RACK

DATE: 02/08/96	CESNA AIRCRAFT COMPANY
DRAWN: ROBERT SCOTT	AIRCRAFT DIVISION
GROUP:	P.O. BOX 7704
CHECK:	WICHITA, KANSAS 67277
SEC'T:	
PRD.J:	
M.E.:	
OTHER:	
FABRICATE PER: CES260A	SIZE: F50N NO.
PROCESS PER: XXXXXXXXXX	DWG NO.
WIRE TERMINATION PER: CES271E	SCALE:
CABLE ASSY - NAV 2 (HONEYWELL)	
F71379	
SHEET 1 OF 1	