

NOTES:

- THIS DRAWING FILED IN PROCADAM.
- SUNBANK ELECTRONICS, INC., PASO ROBLES, CA.
- AFFIX CM2987-5 ID TAG NEAR PLUG.
- ITT CANNON, SANTA ANA, CA.
- ELECTRONIC CABLE SPECIALISTS, FRANKLIN, WI.
- SWITCHCRAFT, INC., CHICAGO, IL.
- PLYLE-NATIONAL CO., CHICAGO, IL.
- GLENAIR INC., GLENDALE, CA.
- BENDIX CORPORATION, SIDNEY, NY.
- AMPHENOL CADRE DIVISION, LOS GATOS, CA.
- MISC. HARDWARE:
 - S2974N3 SOLDER SLEEVE
 - M81824/1-1 SPlice
 - M81824/1-2 SPlice
 - S1367-1-6 TERMINAL
- REFER TO DWG 8654500 FOR GND BLK/STUD LOCATION.
- ALL WIRES PER MIL-W-81044/12, 22 AWG, EXCEPT AS NOTED.

- MATES WITH PHONE PLUG. PART OF MAGNAVOX HANDSET ASSEMBLY.
- MAGNAVOX, FORT WAYNE, IN.
- HANDSET CABLE ASSY IS 8 FEET IN LENGTH. EXCESS LENGTH TO BE STEVED.
17. AN ASTERISK (*) PRECEDING AN UPPER CASE LETTER INDICATES LOWER CASE.
- CHINCH CONNECTOR DIVISION, ELK GROVE VILLAGE, IL.
- AEROSPACE OPTICS INC., FORT WORTH, TX.
- CAS CABLE ASSY IS 12 FEET IN LENGTH. CONNECTOR PF582 IS SHIPPED LOOSE. SHORTEN ASSY AS REQUIRED FOR INSTALLATION.
- INSTALL BEHIND INSTRUMENT PANEL, NEAR THE PHONE CALL ANNUNCIATOR.
- PART OF ARTU CONNECTOR KIT 744319-802 (REF). KIT SUPPLIED WITH ARTU.
- PART OF ARTU TRAY CONNECTOR KIT 744320-802 (REF). KIT SUPPLIED WITH ARTU TRAY.
- PART OF CDBR CONNECTOR KIT 744321-801 (REF). KIT SUPPLIED WITH CDBR.
- PART OF CAS CONNECTOR KIT 743424-801 (REF). KIT SUPPLIED WITH CAS.
- CONNECTORS & BACKSHELLS ARE SUPPLIED AS PART OF ASSEMBLIES.
- PART OF 422650-801 (REF) CABLE ASSEMBLY. PREFABRICATED CABLE ASSEMBLY SUPPLIED WITH ARTU TRAY.
- PART OF DUPLEXER CONNECTOR KIT 105-0041-00 (REF). KIT SUPPLIED WITH DUPLEXER.
- DWG# 8601108 IS THE BASIS FOR THIS DWG.
- AMPHENOL CORPORATION, HAMDEN, CT.
- JOINT ELECTRON DEVICE ENGINEERING COUNCIL

REVISIONS				
SHEET	REV	DESCRIPTION	DATE	APPROVED

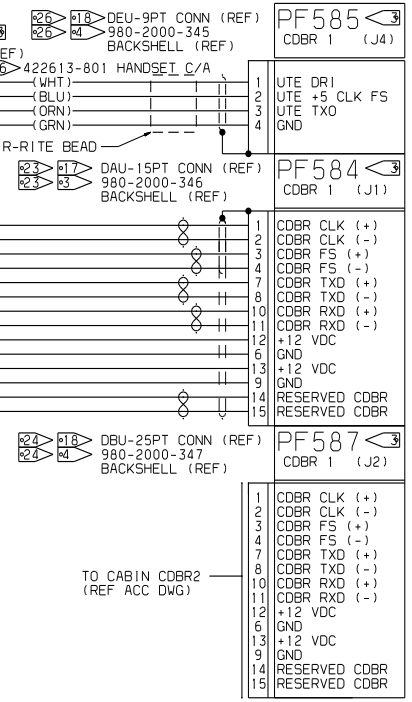
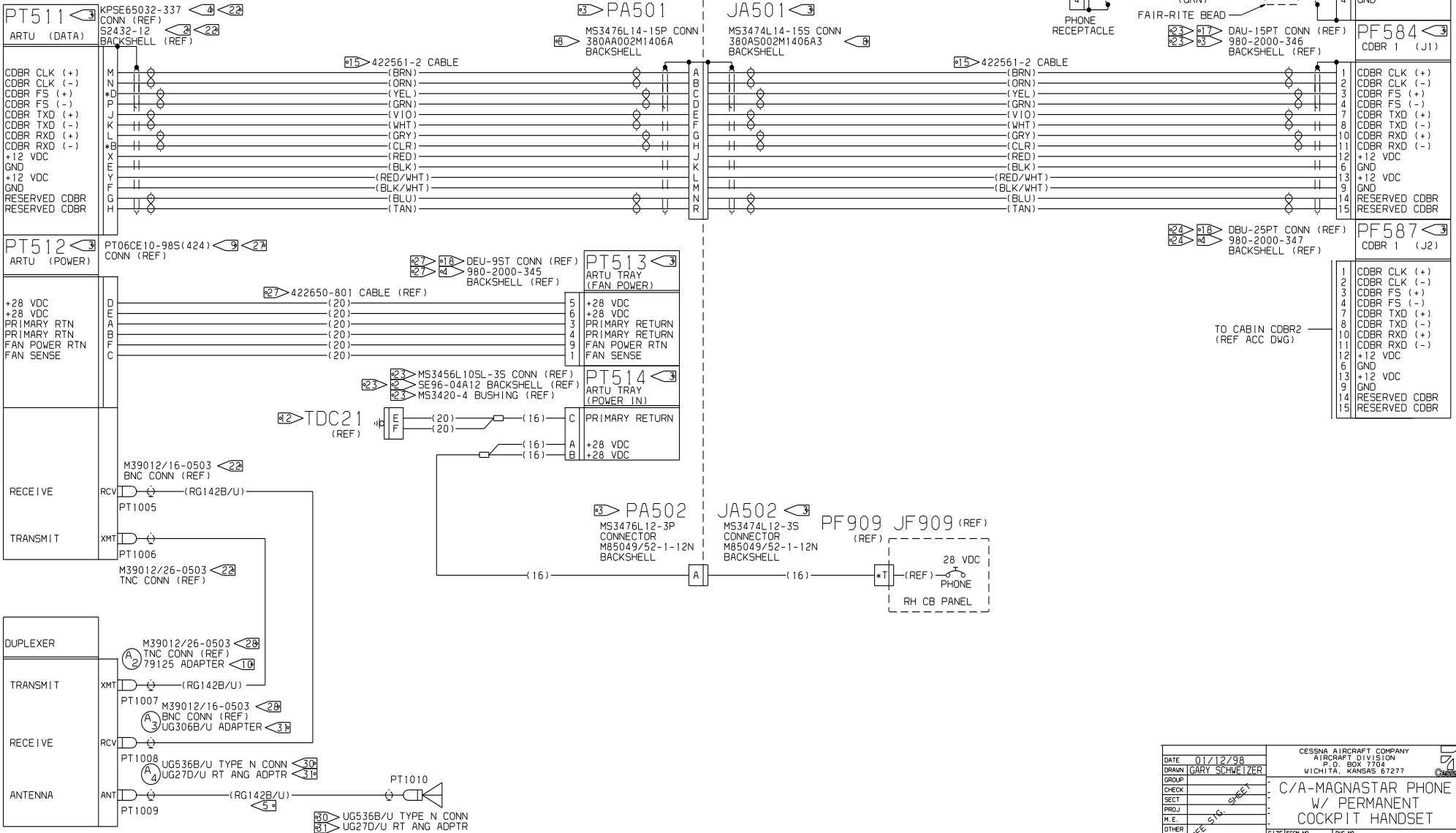

DATE	01/12/98	CESSNA AIRCRAFT COMPANY AIRCRAFT DIVISION P.O. BOX 7704 WICHITA, KANSAS 67277
DRWN	GARY SCHWEITZER	
GROUP		C/A-MAGNASTAR PHONE W/ PERMANENT COCKPIT HANDSET
CHECK		
SECT		
PRD J		
M. E.		
OTHER		SIZE FSOB NO. DWG NO.
FABRICATE PER CES260A		F71379
PROCESS PER XXXXXXXXXX		
WIRE TERMINATION PER CES216		SCALE: PARENT: 8601108 SHEET 1 OF 2

EC565006

REVISIONS				
SHEET	REV	DESCRIPTION	DATE	APPROVED
1	A	BY REVISION:	06/10/98	
1		1) ADDED NOTES 30 & 31.	CGS	
1		2) ADDED P/N 79125 RT ANGLE ADAPTER.		
1		3) ADDED P/N UG3066/U RT ANGLE ADAPTER.		
1		4) ADDED P/N UG270/U RT ANGLE ADAPTER.		
EFF: EC 565006				

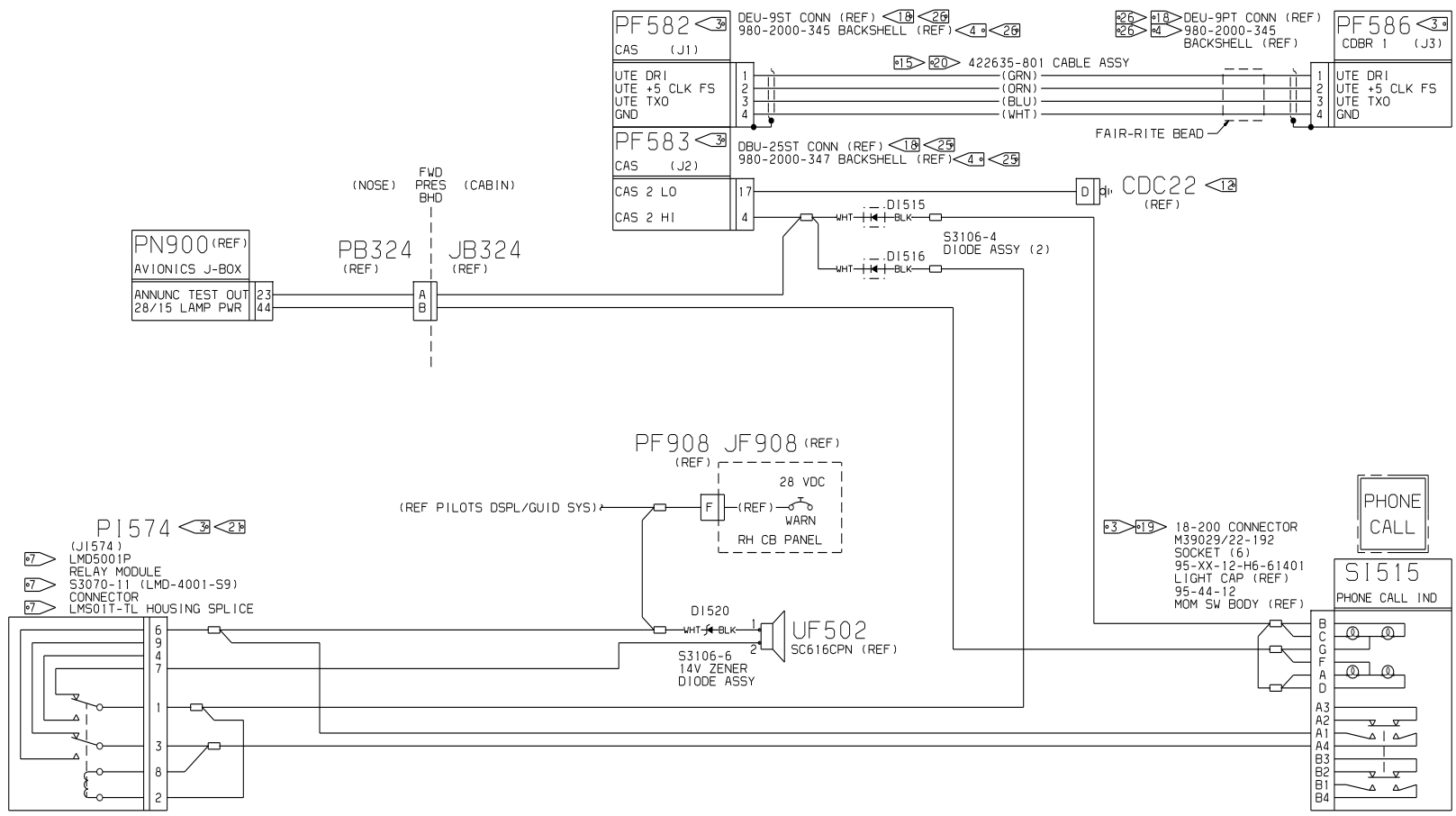

DATE	01/12/98	CESSNA AIRCRAFT COMPANY AIRCRAFT DIVISION P.O. BOX 7704 WICHITA, KANSAS 67277	
DRN	GARY SCHWEITZER		
GROUP		C/A-MAGNASTAR PHONE W/ PERMANENT COCKPIT HANDSET	
CHECK			
SECT			
PRD J			
M. E.			
OTHER			
FABRICATE PER CES260A		SIZE	FSOJ NO.
PROCESS PER XXXXXXXXXXXXX		DWG NO.	
WIRE TERMINATION PER CES271E			
SCALE:	PARENT: 8601108	SHEET 2 OF 2	

EC565006