

NOTES:

1. THIS DRAWING FILED IN CCD.
2. AN ASTERISK PRECEDING A LETTER INDICATES LOWER CASE.
3. IF TELELINK IS INSTALLED, ADDITIONAL DIODE ISOLATION IS ADDED TO 74PN384-22PN808. REFER TO TELELINK DRAWING FOR MODIFICATION.
4. FOR GND/BLOCK STUD LOCATIONS, REFER TO GND/BLOCK STUD INSTL DWG CALLED OUT ON AVIONICS INSTL KIT.
5. REFER TO P/L NOTE 2 FOR PIN/EXTRACTION INFORMATION.
6. TWO CONDUCTOR SHIELDED WIRE PER M27500-**ML2T08 (** - 22AWG EXCEPT AS NOTED).
7. ALL WIRE PER MIL-W-81044/12, 22 AWG EXCEPT AS NOTED.
8. PERMISSIBLE TO DEVIATE FROM SHIELD GROUNDING REQUIREMENTS IN CSAM012.
9. PART OF 249LE-1200-103 TCAS KIT. REFERENCE P/L NOTE 1 FOR INDIVIDUAL KIT P/NS & ASSOCIATED REFDES.
10. LOCATE SPLICE APPROX. 6" FROM PA527 CONN.
11. ANNUNCIATOR OUTPUT CAPABLE OF SINKING 200MA.

REVISIONS				
SHEET	REV	DESCRIPTION	DATE	APPROVED
1	A	BY REVISION: 1) ADDED FLAGNOTE 9.	07/31/03 KSB	
EFF: EC 52743				
1	B	BY REVISION: 1) MOVED WIRES RJ4527-LJ4810, LP8810-87PN808 & SPLICE DN804 ONTO SHEET 2. 2) ADDED A SPLICE AND DIODES DN807 AND DN808. 3) CHANGED (NOSE) TOP ANTENNA COAXIAL COLOR CODES TO AGREE WITH CABIN SIDE.	4/15/04 AJD	
EFF: EC 52743				

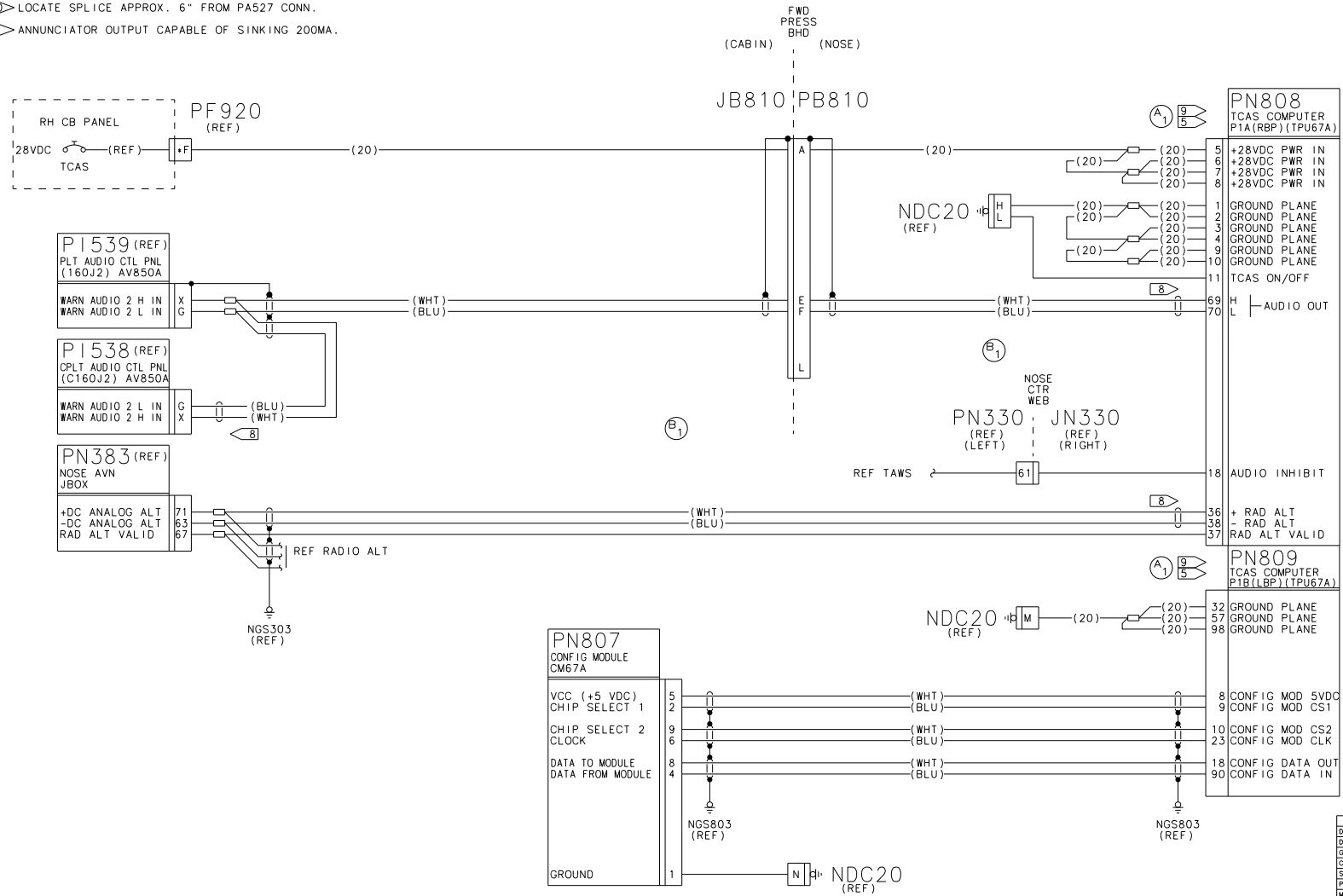

DATE	05/30/03	CESSNA AIRCRAFT COMPANY AIRCRAFT DIVISION P.O. BOX 7704 WICHITA, KANSAS 67277	
DRAWN	K. BURTON		
GROUP		C/A - HONEYWELL TCAS II	
CHECK			
SECT			
PROJ			
M.E.			
OTHER			
FABRICATE PER CSAM005		SIZE FSCM NO.	DWG NO.
PROCESS PER 348XAXXXXXX		F171379	8608136
WIRE TERMINATION PER 2652716		SCALE: NONE	PARENT: 8608130 SHEET 1 OF 3

8608136

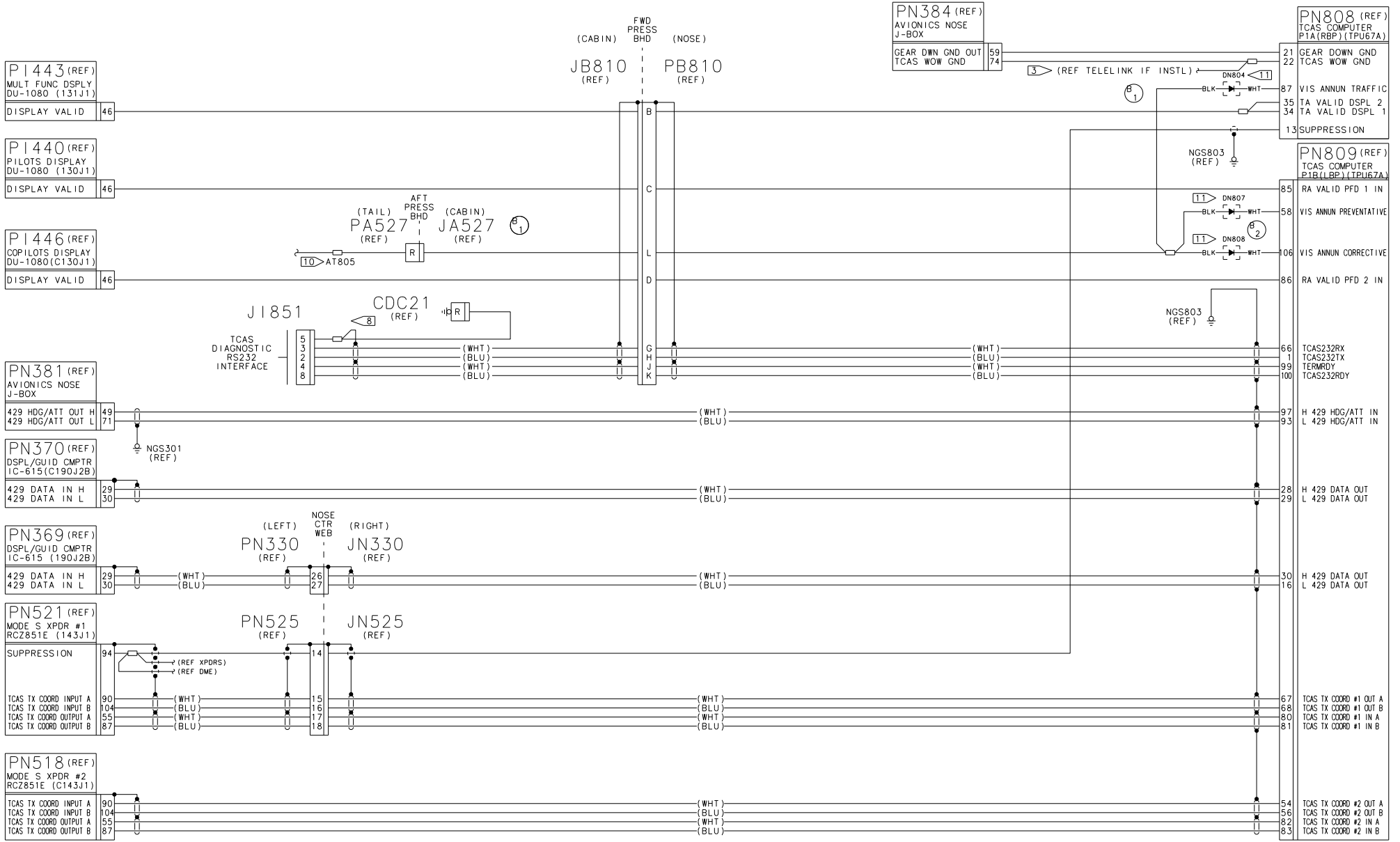

DATE	05/30/03	CESSNA AIRCRAFT COMPANY AIRCRAFT DIVISION P. O. BOX 7794 WICHITA, KANSAS 67277 C/A - HONEYWELL TCAS II
DRAWN	K. BURTON	
GROUP		
CHECK		
SECT		
PROJ		
M.E.		
OTHER		
FABRICATE PER	CSAMDRS	
PROCESS PER	XXXXXXXXXX	
WIRE TERMINATION PER	DS2216	
SIZE	F171379	DWG NO. 8608136
SCALE		SHEET 2 OF 3

8608136

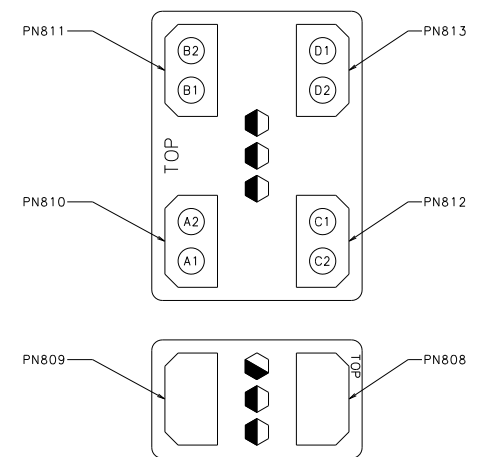
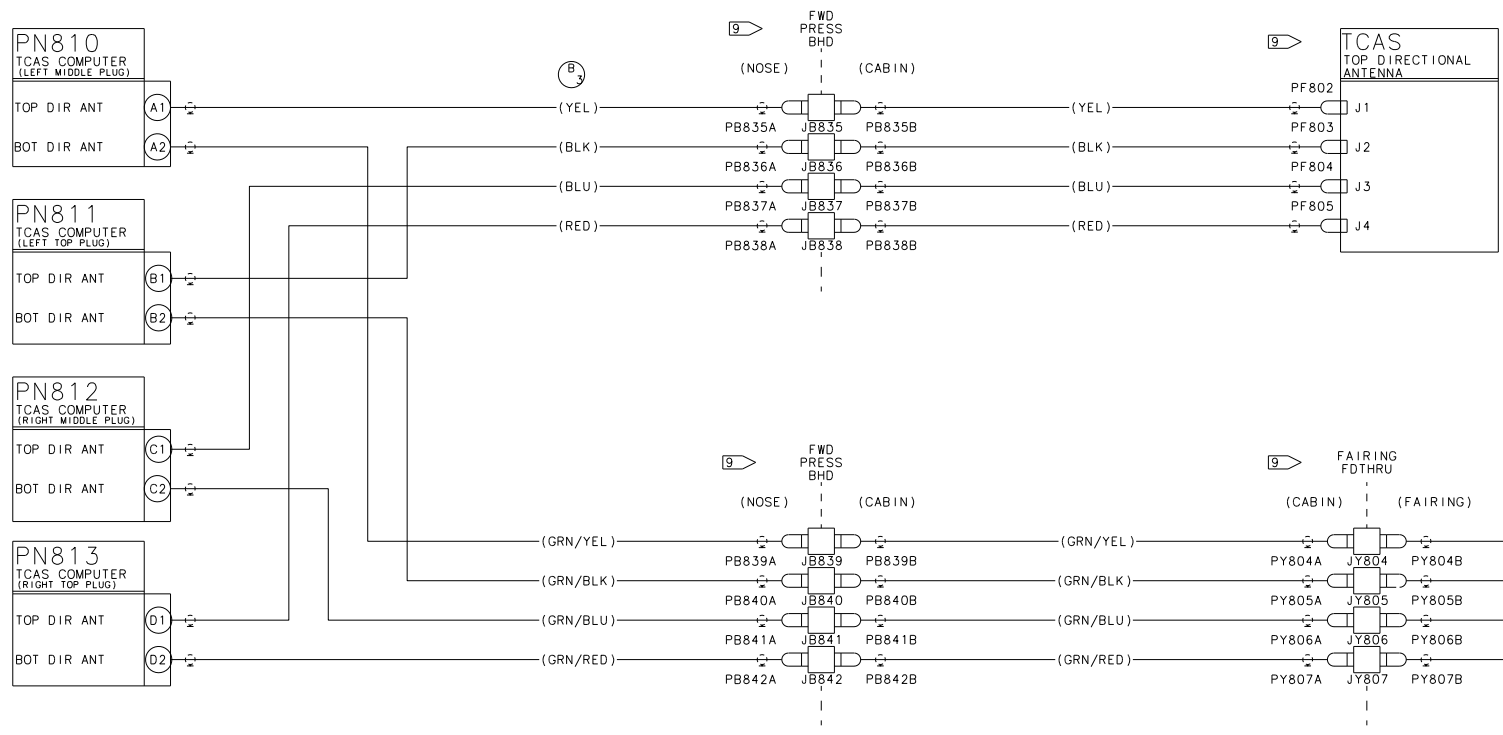

CONNECTOR KEYING AND CONN LOCATION
(FRONT VIEW OF RACK CONNECTOR)

DATE	05/30/03	CESNA AIRCRAFT COMPANY
DRAWN	K. BURTON	AIRCRAFT DIVISION
GROUP		P. O. BOX 7704
CHECK		WICHITA, KANSAS 67277
SECT		
PROJ		C/A - HONEYWELL
M. E.		TCAS II
OTHER		
FABRICATE PER CSAM005	SIZE	FORM NO.
PROCESS PER XXXXXXXXXXXXX	F 71379	DWG NO.
WIRE TERMINATION PER DS22716	SCALE:	8608136

8608136